

STAINLESS STEEL ACCESSORIES

UNIVERSAL BUG DEFLECTOR

INSTALLATION INSTRUCTIONS

1. Pull back plastic coating from the bottom edge of the Bug Deflector approx. ½"
2. Remove Plastic coating around all bolt holes.
3. Attach both brackets with slots to the backside of the Bug Deflector. Do not tighten 10-32 screws with locknuts all the way. Allow brackets to slide freely.

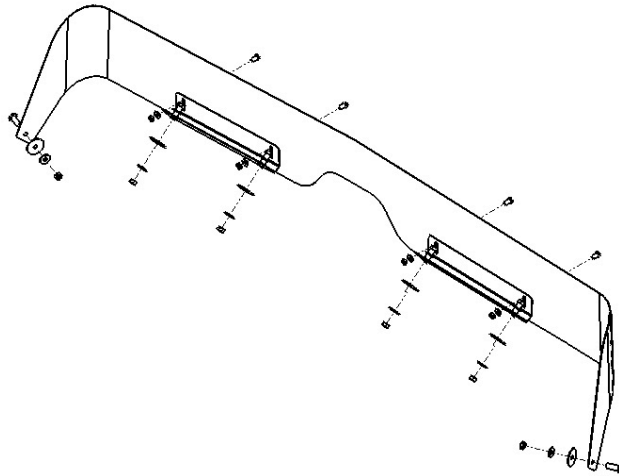

4. Install rubber channel to bottom edge to protect from scratching.
5. Place Bug Deflector on hood directly behind grill bezel or grab handle (on some models designed without grill bezels). Hold Bug Deflector in desired position, making sure the Bug Deflector is centered on hood, and parallel with grill.
6. Mark all four holes through the brackets and two end holes onto the hood.
7. Set aside Bug Deflector.
8. Drill 9/32" holes into hood and attach brackets and bug deflector to hood.
9. Tilt hood to forward position.
10. Pull bug deflector ends tight against hood and attach remaining screws, nuts, and washers.
11. Tighten the four small screws (10-32x1/2") on the face of the Bug Deflector, and pull off remaining plastic coating.

***NOTE**

For some applications where the bug deflector has a cut-out for a grab handle, it is strongly advised that the rubber edging be installed around the cut out.

STAINLESS STEEL ACCESSORIES

Application Procedures for Pressure-Sensitive Body Side Moldings

Outlined below are the recommended procedures for applying pressure-sensitive body side moldings (BSM).

These procedures address three key points for a successful BSM application.

1. The Body of the vehicle must be clean and dry to achieve the best adhesion.
2. The pressure-sensitive adhesive on the molding must not be contaminated during the application.
3. The molding must be applied to achieve complete contact (bond) of the adhesive to the vehicle. (i.e. Maximum wet-out).

A. Installation Area:

1. The installation area should be kept reasonably clean. Any airborne dust, oils, etc. may contaminate the vehicle or BSM adhesive and reduce the bond of the tape.

B. Vehicle Surface Preparation:

1. The vehicle surface should be washed with an appropriate solvent, one commonly used system is a 70% mixture of Isopropyl Alcohol and water (Rubbing Alcohol). To assure removal of all contaminants it may be necessary to first wipe with **TG Prep**, then use the 70% Isopropyl Alcohol mixture.

* Use clean lint free wiping cloths or disposable wipes such as Kimwipes.

* Reprocessed rags should not be used as they may contain wax or residue.

2. After washing, the vehicle surface should be thoroughly dried. Again use a clean, dry, lint free cloth.

3. Vehicle surface application temperatures of 80°F (25°C) to 110°F (44°C) are recommended for best tape adhesion. The warmer surface will help wet-out the adhesive on the tape.

IMPORTANT NOTE:

During cold weather applications the vehicle surface can be heated with a heat gun or heat lamps, but do not heat the surface of the molding with a heat gun. Application of the BSM at temperatures below 64°F (17°C) or above 110°F (44°C) must be avoided.

C. Body Side Molding Preparation:

1. The BSM should be stored at room temperature in a clean dry area. Cold temperatures require heating to warm the molding to the proper application temperature (i.e. Floor heater or Defroster of vehicle). There is no damage to the tape or molding stored at colder temperatures, but moisture and condensation must be avoided.
2. **The molding should be heated up to 80°F (25°C) for application.** This will soften the molding, making it easier to conform to the vehicle contours, as well as improve adhesive wet-out.
3. The liner on the adhesive should not be removed until application to the vehicle. This will help prevent contamination of the adhesive surface.

STAINLESS STEEL ACCESSORIES

D. Body Side Molding Application:

1. Align the molding with a key feature such as the front and rear bumpers or with a body line to ensure proper molding alignment. Placing ½” masking tape along the desired installation area is an excellent guide for applying the molding straight.
2. Use molding cutters to trim the molding at door jams and body seams. Chrome moldings must be cut with the blade of the cutter coming down on the surface of the chrome finish (Seal all cut ends of chrome moldings with TG End Seal). Be certain to leave enough room for the door to open properly after the molding has been installed. (Bevel cut if necessary).
3. Remove the liner from the tape as you are applying the molding to the vehicle. Be careful not to contaminate the adhesive. Common sources of contamination are: oil from the applicator hands, dust or lint from clothing, work tables, or the floor. Do not touch the adhesive at any time. Contaminated moldings should not be used.
4. Apply the moldings with a rolling motion to prevent entrapment of air between the tape and the vehicle surface. Use firm hand pressure to ensure good adhesion of the molding.
5. A roll down with a hard rubber hand roller (TG Roller) is necessary to assure complete wet-out of the adhesive to the vehicle surface. Apply firm pressure while rolling the molding to properly wet-out the adhesive.
6. Check the edges of the molding to assure good tape adhesion. Re-roll with more pressure as necessary to achieve a good bond. Use the blunt end of the roller or screwdriver to press out all molding ends to ensure adhesive bond.